



**EVINRUDE**<sup>®</sup>



**THE POWER OF CHOICE**



**EVINRUDE**®



**THE POWER OF CHOICE**



**EVINRUDE**<sup>®</sup>



**THE POWER OF CHOICE**



**EVINRUDE**<sup>®</sup>



**THE POWER OF CHOICE**





**EVINRUDE**®



**THE POWER OF CHOICE**





# Welcome to a new era in outboards.

Introducing a revolutionary concept in outboards – a choice. Now with Evinrude E-TEC, choose cutting-edge over commonplace. Choose more torque over more talk. Choose more time on the water over more time in the shop. Choose an outboard that perfectly matches your boat and your type of boating. Choose Evinrude E-TEC, the outboard that performs, and looks, like no other outboard in the world.

## TABLE OF CONTENTS

Introducing the Evinrude® E-TEC™ G2™	4-9
Choose Unrivaled Performance	10-11
Choose Bold, Breakthrough Design	12-13
Choose Unmatched Lifetime Value	14-15
Choose the Cleanest <sup>1</sup> Technology	16-17
Choose Your Evinrude Engine	18-31
• E-TEC G2 Series	20-21
• H.O. Series	22-23
• V-6	24-25
• V-4	26-27
• Inline	28-29
• Portables	30
• Multi-fuel Engines	31
Tillers and Oil	32-33
Controls	34-35
Propellers	36-37
Engine Specifications	38-41

1. Based on BHP internal testing versus competitive combustion outboards. Accurate at time of printing.



INTRODUCING THE ALL-NEW  
**Evinrude E-TEC G2.**





# The outboard of the future. Available today.

**We invented the outboard. Now we've created the outboard of the future. Introducing the Evinrude E-TEC G2.**

The new era of outboards is all about choice. When BRP engineers began designing the Evinrude E-TEC G2 outboard engine, they chose to start fresh, with a clean sheet of paper. They chose to dedicate months studying engine thermodynamics using advanced computational fluid dynamics software developed by the University of Wisconsin. They chose to craft the entire engine around the moment of combustion and developed the first outboard engine block designed specifically for direct-injection technology. And with the freedom to develop any technology, they chose to stand by direct-injection two-stroke, because it's simply the best technology for the outboard engine application.

The results were startling, and now boaters truly do have a choice. Choose PurePower Combustion to experience best-in-class torque<sup>1</sup>, emissions<sup>1</sup> and fuel efficiency<sup>1</sup>. Choose an engine designed to fully integrate into your boat with Dual Axis Rigging, intelligent controls and gauges, and a fully customizable, bold, breakthrough look. Choose an engine that requires no dealer-scheduled maintenance for 5 years or 500 hours and is backed by a 5-year engine and corrosion warranty<sup>2</sup>, offering the most lifetime value of any outboard in the industry. Choose the cleanest combustion outboard on the planet. Choose an Evinrude E-TEC G2.

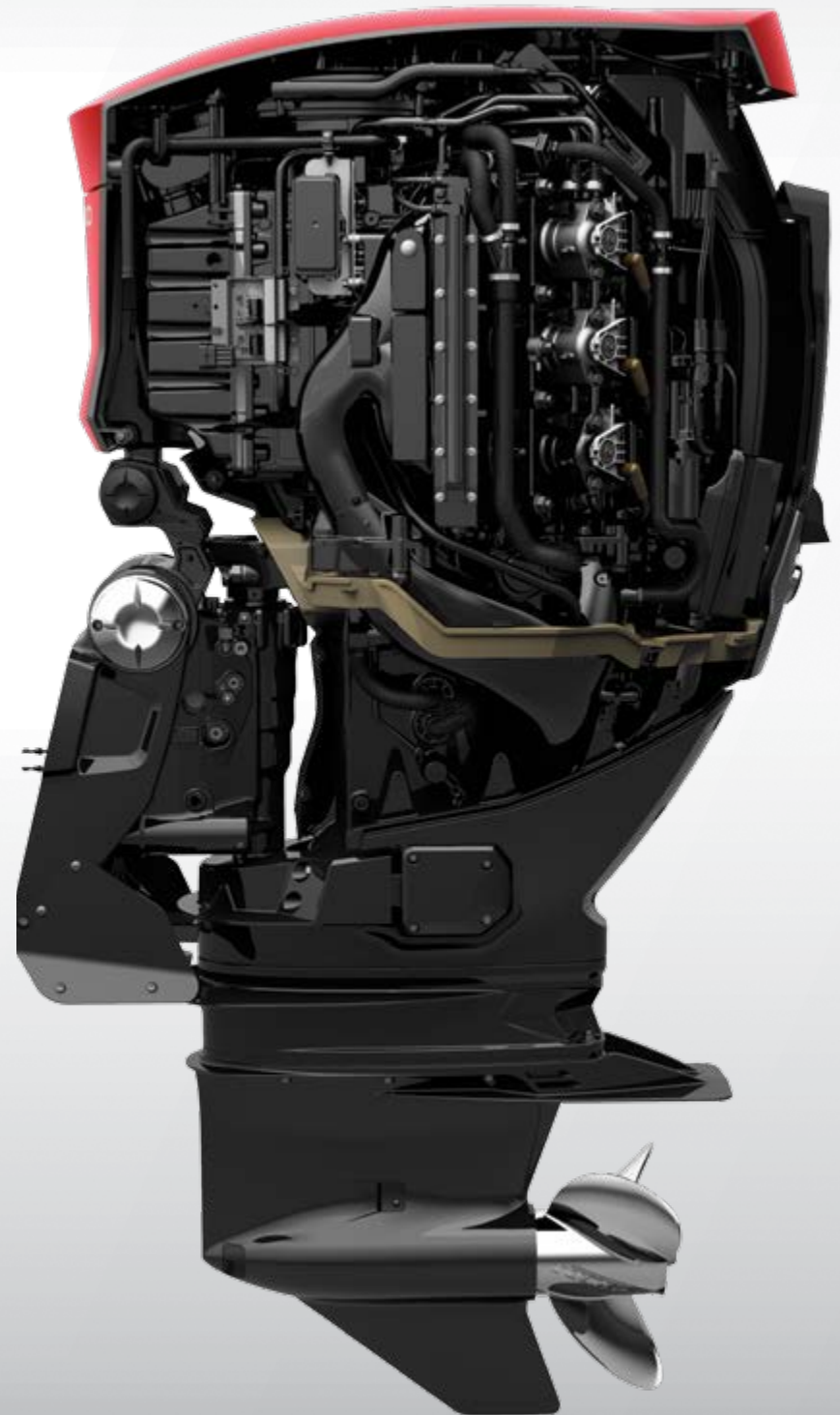

1. Based on BRP ICOMIA Fuel Efficiency Testing of BRP and competitive engines.  
2. Terms and conditions apply. Available in select markets. Please consult your local BRP representative for full details.  
3. Based on BRP internal testing versus competitive combustion outboards. Accurate at time of printing.

# Evinrude E-TEC G2 Exclusive Technologies



## PurePower Combustion

With the help of computer modeling, we looked inside an operating engine and created the most efficient piston/cylinder design in the industry, giving you better performance while also providing 15% more fuel efficiency versus competitive outboards<sup>3</sup>.



## Starboard-Starboard Engine Design

We've turned the outboard industry on its side. With the new Starboard-Starboard design, you get faster acceleration, better hole shots and more towing power as well as a more reliable engine.



## Dual Axis Rigging System

No more clutter in the back of your boat. The Dual Axis Rigging System routes engine cables through just one tube, giving you more useable space at the transom while creating less friction and premature wear.



## SLX Gearcase

The all-new, sleek hydrodynamic SLX Gearcase reduces steering effort without sacrificing speed.



## Dynamic Power Steering

Dynamic Power Steering is integrated directly into the midsection. It's designed to adapt steering resistance to the boat application, delivering superior handling and more control in tight turns and big water.

# Design your own Evinrude E-TEC G2.

The Evinrude E-TEC G2 engine is the world's first outboard with customizable side, top and front panels, as well as accent colors. Now you have hundreds of different color combinations to choose from. Create an Evinrude E-TEC G2 to perfectly match your boat, or get an exclusive boat package with matching Evinrude E-TEC G2 colors.



## STEP 1 CHOOSE YOUR HORSEPOWER.



## STEP 2 CHOOSE FROM 5 SIDE PANEL COLORS.



**STEP 3** CHOOSE FROM 5 TOP AND FRONT PANEL COLORS.



**STEP 4** CHOOSE FROM 14 ACCENT COLORS.

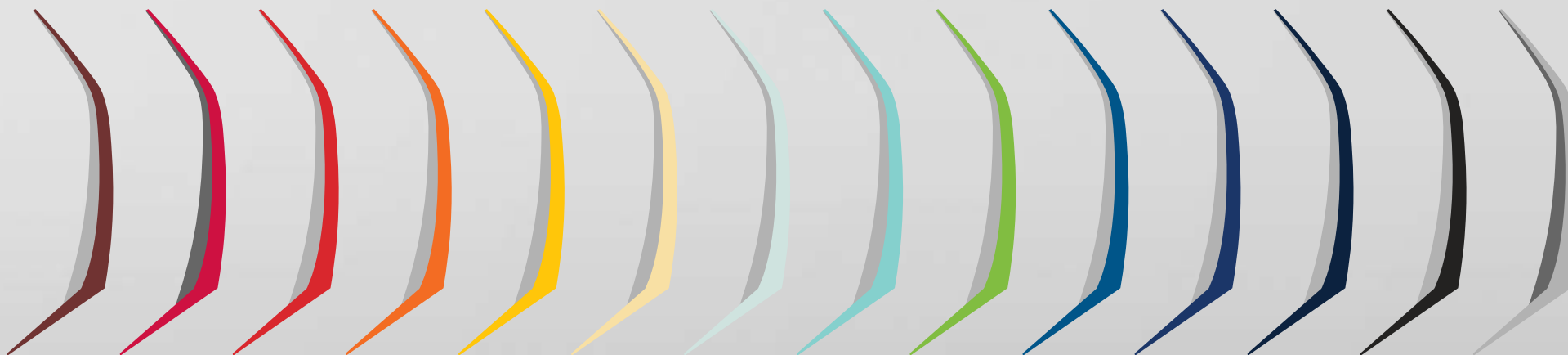

**DESIGN YOUR OWN EVINRUDE E-TEC G2 AT [ChooseYourETEC.com](http://ChooseYourETEC.com)**

Choose Unrivaled Performance.



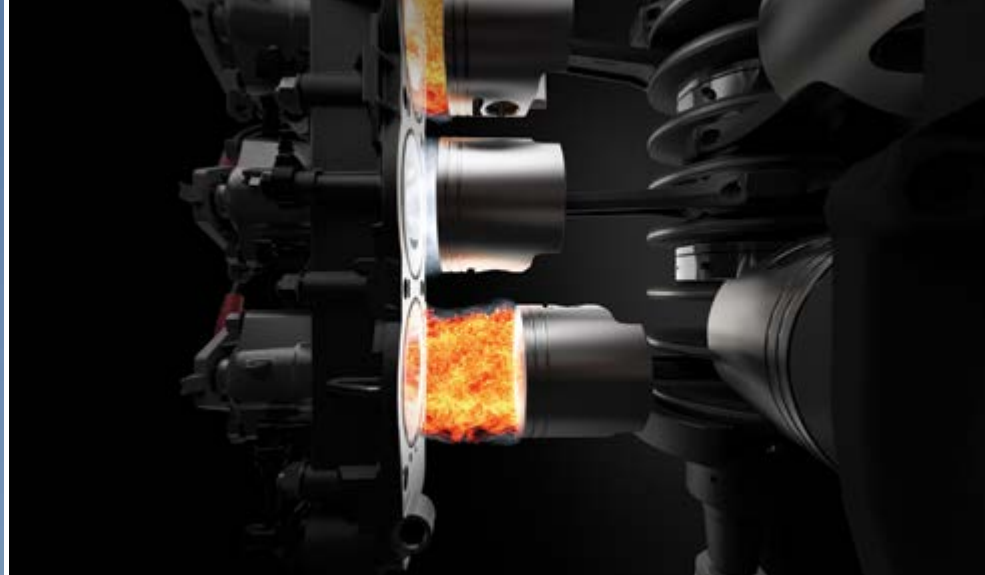

## BEST-IN-CLASS TORQUE

With 20% more torque than competitive outboards, the PurePower Combustion process of the Evinrude E-TEC G2 delivers the most torque in its class.<sup>1</sup> By precisely mixing the perfect 14:1 air and fuel ratio, it also provides even faster acceleration, more stable RPMs and 15% more fuel efficiency.<sup>2</sup> In fact, every Evinrude E-TEC brings unbeatable low-end torque because of direct injection two-stroke technology.

## BUILT TO OUTPERFORM EVERY OTHER OUTBOARD IN THE WORLD.

Since its introduction in 2003, the direct-injected Evinrude E-TEC has been dominating the industry with best-in-class performance that's the envy of every boat owner without one. It uses the most precise amount of fuel required at every RPM, so not a single drop is wasted. And because every stroke is a power stroke, it jumps out of the hole and every time you accelerate.

## SUPERIOR POWER-TO-WEIGHT RATIO

With significantly fewer moving parts than competitive four-strokes, Evinrude E-TEC engines boast the best overall power-to-weight ratio across many horsepower segments.<sup>3</sup> And the integrated features of the Evinrude E-TEC G2 eliminate the need for additional components, reducing the overall weight of your boat.



## REFINED HANDLING

The Evinrude E-TEC G2 features a new, fully integrated i-Trim, which automatically provides the most optimal trim, and Dynamic Power Steering for superior boat handling. The sleek and strong, hydrodynamic SLX Gearcase increases acceleration and reduces steering effort without sacrificing speed.

1. Based on BRP testing and advertised features of each competitive manufacturer at time of printing.  
2. Based on BRP ICOMIA Fuel Efficiency Testing of BRP and competitive engines.  
3. Based on BRP testing and advertised weights of each competitive manufacturer at time of printing.

Choose Bold, Breakthrough Design.





## HUNDREDS OF COLORS COMBINATIONS AVAILABLE

Choose from 5 side panel colors, 5 top and front panel colors, and 14 accent colors to design an engine to perfectly match your boat. Design your own Evinrude E-TEC G2 at [ChooseYourETEC.com](http://ChooseYourETEC.com).



## FULLY INTEGRATED DIGITAL CONTROL

Everything from the gauges to the throttle has been completely redesigned to give you better command of your Evinrude E-TEC G2 engine.

## THE FIRST OUTBOARD EVER DESIGNED TO PERFECTLY MATCH YOUR BOAT, INSIDE AND OUT.

Evinrude is committed to delivering the best engine for your style of boating, as evidenced by the Evinrude E-TEC and H.O. Series. Now the new Evinrude E-TEC G2 offers the first and only customizable look, the cleanest rigging and fully integrated digital controls to perfectly match your boat, inside and out.

## INDUSTRY-FIRST CLEAN RIGGING

The proprietary Dual Axis Rigging System on the Evinrude E-TEC G2 routes each engine's cables through a single rigging tube, giving you more useable space at the transom while creating less friction and premature wear.





Choose Unmatched Lifetime Value.

## INDUSTRY-LEADING MAINTENANCE SCHEDULE

The Evinrude E-TEC redefined low maintenance with 3 years or 300 hours of no dealer-scheduled maintenance. The Evinrude E-TEC G2 once again sets the standard for ease of ownership by only requiring dealer-scheduled maintenance every 5 years or 500 hours.



## LESS OUT OF POCKET, MORE OUT ON THE WATER.

Evinrude E-TEC engines are built to give you the best value for your dollar with more time on the water and less time in the shop. It means lower ownership costs and less hassle. And with the new Evinrude E-TEC G2, you get the most lifetime value on the water.

### 5-YEAR ENGINE AND CORROSION WARRANTY

It's the industry's best coverage with a 5-year engine warranty<sup>1</sup> and 5-year non-declining corrosion warranty. No one else even comes close to that kind of peace of mind.



### BEST-IN-CLASS FUEL EFFICIENCY

With an Evinrude E-TEC G2, you'll spend a lot less at the pump because you'll burn 15% less fuel than the leading four-stroke. That means more money in your pocket and more time on the water.<sup>2</sup>



### WORRY-FREE OWNERSHIP

All Evinrude E-TEC engines feature Auto-Storage/Winterization, no break-in period and no oil changes, ever.

1. Terms and conditions apply. Available in select markets. Please consult your local BRP representative for full details.  
2. Based on BRP ICOMIA Fuel Efficiency Testing of BRP and competitive engines.



Choose the Cleanest<sup>1</sup> Technology.



## 100% GLOBAL EMISSIONS COMPLIANT

No matter where in the world your boating experience takes you, the Evinrude E-TEC G2 is welcome.



## THE CLEANEST<sup>1</sup> OUTBOARD IN THE WORLD.

You already find Evinrude E-TEC engines operating on some of the most heavily regulated bodies of water in the world. But that wasn't good enough. So we designed the Evinrude E-TEC G2 with the future in mind. From Day 1, we questioned the status quo, challenged convention and rethought every aspect of the outboard, from the inside out. The result takes our clean-burning, fuel-efficient legacy to the next level, making Evinrude E-TEC G2 the cleanest combustion outboard engine in the world.



### LOWEST EMISSION LEVELS<sup>1</sup>

Simply put, a more efficient engine is also a cleaner engine. In fact, the PurePower Combustion of an Evinrude E-TEC G2 is so clean burning that it's showing 75% fewer regulated emissions than competitive four-strokes, keeping waters clean for you and generations to come.



### BEST-IN-CLASS FUEL EFFICIENCY<sup>2</sup>

The PurePower Combustion of an Evinrude E-TEC G2 efficiently mixes a perfect 14:1 air and fuel ratio, ensuring every drop is burned, not wasted.



1. Based on BRP internal testing versus competitive combustion outboards. Accurate at time of printing.  
2. Based on BRP ICOMIA Fuel Efficiency Testing of BRP and competitive engines.

# Choose Your Evinrude.

We don't start designing outboards on paper. We start on the water—from the boater's perspective. We spend time with boaters, asking them what they need from an outboard and what they don't. Their answers guide us as we create outboards specifically designed for their particular boating experience. That's why boaters choose Evinrude E-TEC. We think that's why you will too.

**RANDY LINDEN,**  
E-NATION Member

“The simple, but high-tech, direct-injected two-stroke design of the E-TEC is what sets Evinrude apart.”



**E-TEC G2 SERIES** 300 HP-200 H.O.

20

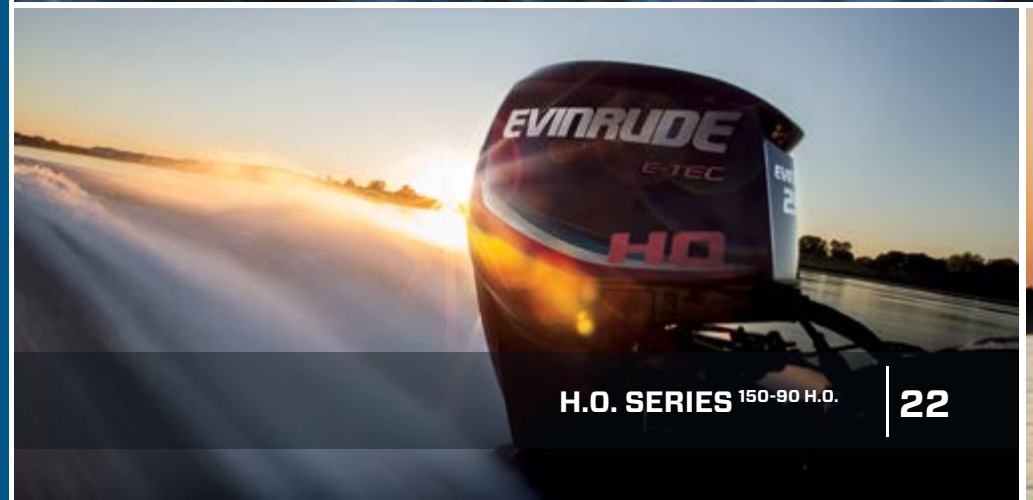

**H.O. SERIES** 150-90 H.O.

22



**V-4** 130-115 HP

26



**INLINE** 90-25 HP | **28**



**MULTI-FUEL ENGINES** 55-30 HP | **31**



**V-6** 200-150 HP | **24**



**PORTABLE** 15-3,5 HP | **30**



**E-TEC G2 SERIES** 300 HP-200 H.O.





## THE OUTBOARD OF THE FUTURE. AVAILABLE TODAY.

The new era is all about choice. The all-new Evinrude E-TEC G2 not only gives you best-in-class torque, but as the first outboard ever designed to perfectly match your boat inside and out, you get to choose from hundreds of different color combinations. Choose the Evinrude E-TEC G2 and get the industry's cleanest rigging, 5 years or 500 hours with no dealer-scheduled maintenance, and the cleanest<sup>1</sup> outboard technology on the water.



### RX4<sup>®</sup> SERIES PROPELLER

A no-compromise four-blade propeller designed for the Evinrude E-TEC G2, it's optimized for traction and rough water performance with industry-leading speed, acceleration and fuel economy. It delivers superior bow lift on larger boats and does not slip in turns.

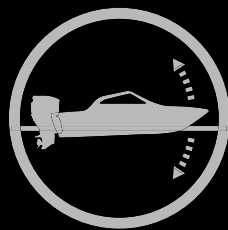

### ALL-NEW I-TRIM SYSTEM

Another exclusive Evinrude E-TEC G2 feature is the i-Trim system. i-Trim automatically trims the boat out for any given speed and can make even the most novice of drivers trim their boat like a pro.

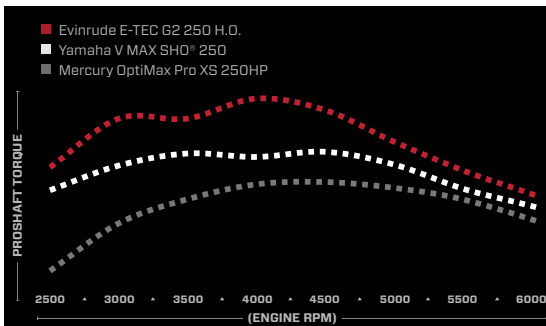

### BEST-IN-CLASS TORQUE

The natural two-stroke advantage paired with direct injection and the combustion system of an Evinrude E-TEC G2 means 20% more torque<sup>1</sup>. Hole shots? More like slingshots.



### EVINRUDE I-DOCK

Whether you own a power catamaran, a high performance cruiser or have an offshore center console, the i-Dock takes the stress out of docking and launching a dual-engine boat.

<sup>1</sup> Based on BRP internal testing versus competitive combustion outboards. Accurate at time of printing.

# H.O. SERIES 150-90 H.O.





## LIKE PUSHING LIMITS?

Then take a closer look at our High Output Series. Because they push limits about as far as they can go – and come with everything it takes to handle it. Like a high-performing SLE Magnum gear case that significantly increases water flow to the engine and provides increased cooling ability and capacity. High-quality gears with super-pure, extra-tough metallurgy. And stiffer engine mounts for superior handling and control at high speeds. If you're looking for that extra bit of mph, this is it. For bass boats, check out our H.O. V-6 engines that deliver explosive hole shots and incredible throttle response.



### PERFORMANCE-TUNED EMM

Designed to maximize performance, all H.O. models feature a specially tuned EMM (Engine Management Module) that controls ignition timing and fuel injection duration for more power and speed while optimizing fuel efficiency.



### HIGH-SPEED MOTOR MOUNTS

Stiffer engine mounts provide superior handling and control at high speeds.



### STRATIFIED COMBUSTION PROCESS

Evinrude E-TEC's advanced form of direct fuel injection features stratified combustion. At idle and slow speeds, the engine's computer uses just a small portion of each cylinder in the combustion process to provide superior fuel efficiency and ultra-low emissions.



### NASA PISTON ALLOY

Developed by NASA engineers, our piston alloy is 2.5-times stronger than conventional alloys. This means increased durability and longer engine life.



### HIGH PERFORMANCE GEAR CASE

The nose cone water pickups of the SLE (Straight Leading Edge) provide maximum water intake in all conditions. This results in a cooler running engine for the ultimate in engine durability and reliability.



V-6 200-150 HP



## BIGGER ENGINES. BIGGER LEAD.

More displacement, more torque, more top end than you'll likely ever need. For offshore riders, that means you're on plane faster and well equipped to handle heavy seas. Plus, thanks to a complete corrosion package, you'll get longer engine life out of your Evinrude E-TEC engine in even the most demanding applications. Our V-6s also come equipped with high-performance gear cases and advanced fuel injectors that maximize performance as well as efficiency. Which goes to show these Evinrude E-TECs aren't just bigger. They're better.

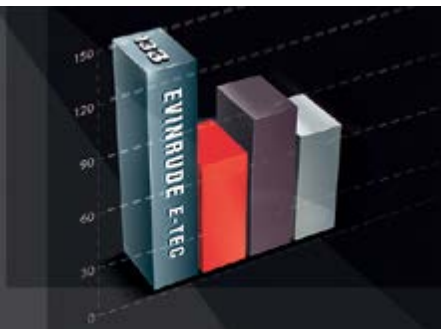

### 133-AMP ALTERNATOR<sup>1</sup>

All V-6 engines feature a powerful dual voltage alternator that produces 133 amps, with a full 50 net amps available for powering the boat equipment and onboard electronics. And unlike competitive models, our charging system is beltless and low-maintenance.



### SECONDARY WATER INLETS

Cooling ability and capacity are increased by the addition of a second set of water inlets in the nose of the gear case. This results in cooler engine operating temperatures and longer engine life.



### SS STEERING ARM AND PIVOT SHAFT ASSEMBLY

Built from high-grade, 304 stainless steel, the steering arm and pivot shaft assembly won't rust or corrode, resulting in longer engine life and less maintenance. Featured on most models.



### TILT LIMIT SWITCH

Allows you to limit the amount of tilt to prevent damage from the engine hitting the splash well and/or transom.



### LOW RFI IGNITION WIRES

Specifically designed not to interfere with your onboard electronics, so you can catch more fish and see things more clearly.

1. Variable Voltage Computer Controlled 133 amps. Current amp calculated at 13.5 V. Net dedicated battery charging power output is 50 amps.



V-4 130-115 HP



## MORE IN THE MIDDLE.

With a variable tuning exhaust valve to boost low-end torque and top-end speed, and a cowling design to direct airflow and provide more power and enhanced performance, these engines pack a big punch. Their excellence really shines on runabouts. With less weight, they get you on plane faster. They operate cleanly and quietly, with nothing to get in the way of the fun.



### POWER VALVE

An Evinrude E-TEC exclusive, this variable power valve precisely tunes the engine for both strong low-end power and faster top-end speed, allowing our 115 hp and 130 hp to outperform the competition.



### POWER STROKE EVERY REVOLUTION

When compared to competitive four-stroke engines, Evinrude E-TECs develop twice as many power strokes. That means more low-end torque for quicker hole shots and more power to plane a heavy load or pull a skier out of the water.



### COUNTER ROTATION

Counter rotation reduces steering torque and improves boat handling in multiple-engine applications.



### AIR INLET

An advanced air-intake design located on the rear of the engine cover keeps water out while providing more airflow to the engine for increased performance and more top-end speed.



### LOW PROFILE

The low-profile, nonobstructive design of our engines means they won't get in your way. Whether you're fishing, tubing or skiing, our 60° V-4 configuration allows you the freedom to do what you want, when you want.

INLINE 90-25 HP







## SMALLER ENGINES. BIGGER PERFORMANCE.

Sure, our engine options in the 25 to 90 hp range are lightweight. But these Evinrude E-TEC outboard engines are also extremely tough, with plenty of electrical output. Their adjustable tiller handles give you more ergonomic comfort and better handling. Their Fast-Rise Inductive Ignition provides longer spark plug life and smoother running, while the blow-off valve flushes away sand and other clogging debris for exceptional durability. And to top it all off, our 25-hp and 30-hp options deliver the slowest trolling speeds of any outboard in their class, making them the perfect outboard for your multispecies or aluminum boat.

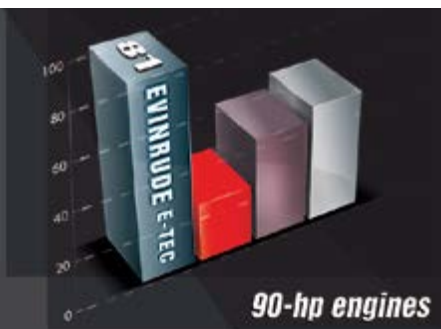

### 81-AMP ALTERNATOR<sup>1</sup>

With up to twice the charging capacity of the competition, it's the best in its class. Evinrude E-TEC outboard engines deliver the electrical power you need to run your onboard electronics without running down your batteries.



### ONBOARD OIL TANK

The oil tank is located under the motor cover with easy access to fill. No oil tank is needed in the boat.



### LARGE-DIAMETER, HIGH-THRUST GEAR CASE

Larger and stronger gears allow for larger propellers and more thrust, as well as increased durability and longer engine life.



### FOCUSED ENGINE MOUNTS

Robust brackets provide unsurpassed durability, while our focused motor mounts reduce vibration for hours of smooth, comfortable operation.



### TOUCH TROLL, ELECTRONIC IDLE SPEED CONTROL

Unlike typical four-stroke engines, 25-hp and 30-hp models let you find the right trolling speed with the touch of a button. Touch-Troll lets you electronically adjust engine speeds in 50-rpm increments.

1. Variable Voltage Computer Controlled 81 Amp. Current amp calculated at 13.5 V. Net dedicated battery charging power output is 25 amps.



## PORTABLES 15-3,5 HP

### COMPACT. SIMPLE. CONVENIENT.

Evinrude Portable Engines have a lot of advantages to offer anyone looking for the best small engines available. From their easy-start ignition system, to the integral fuel tank, to the flow-through propeller for quiet running, these portables have everything you need to make your adventure or experience on the water more enjoyable.

Great on-the-water experiences start here: Evinrude portable outboards

#### 81-AMP ALTERNATOR

With up to twice the charging capacity of the competition, it's the best in its class. Evinrude E-TEC outboard engines deliver the electrical power you need to run your onboard electronics without running down your batteries.

#### CD IGNITION AND A FAST-IDLE CHOKE SYSTEM

Evinrude Portable Engines make boating that much fun, with easier and faster starting, as well as adjustable steering friction for reduced steering effort and fatigue.

#### EFFORTLESS AND UNCOMPLICATED

Operating a portable outboard shouldn't be complicated. The Evinrude Portable Engines, with their front mount shift levers, shallow water drive and power tilt, are made to make your next trip on the water the best ever.



## MULTI-FUEL ENGINES 55-30 HP

### **ANY TIME. ANY PLACE. ANY FUEL.**

To complement the line-up of rugged, reliable engines, Evinrude offers government and commercial customers a line of special multi-fuel models, optimized for minimal operating sound levels and ready to run all day on everything from gasoline to kerosene – even jet fuel. They're designed for use in the most demanding conditions and where stealth, performance reliability, and readiness for anything are highly prioritized.

## Ready for whatever comes their way: Evinrude multi-fuel engines

### **BUILT TO MILITARY SPECIFICATIONS**

Every day, the US military and other government forces around the world depend on MFE technology to complete their missions and get their personnel home safely. Evinrude builds its MFE engines to meet even their toughest requirements.

### **FIRST IN MULTI-FUEL CAPABILITY**

The first outboards ever capable of running on multiple fuel types, Evinrude MFE engines can operate on kerosene, JP-4, JP-5, JP-8, Jet A and Jet B as well as standard gasoline. Change fuel settings at the flip of a switch, without compromising performance..

### **OPTIONAL PUMP JET PROPULSION**

Affording additional safety benefits and performance targets for a wider variety of applications, Evinrude MFE outboards offer optional propulsion without a propeller. A unique design attaches a large impeller unit to a full gearcase for superior thrust compared to conventional jet pumps.

# Better tillers. Better control.

## OUR TWO UNIQUE TILLER HANDLES COVER ALL THE ANGLES.

With all the features and all the controls right at your fingertips. And fully adjustable to maximize comfort and control at your various running speeds.

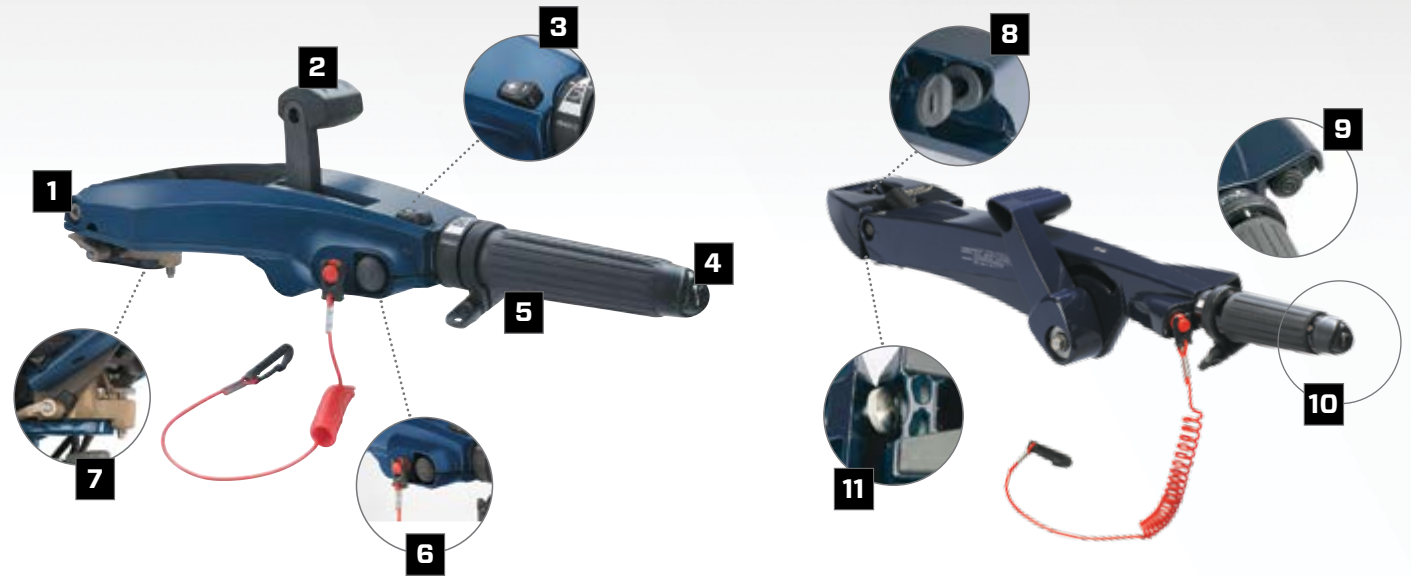

90°

### THREE VERTICAL POSITIONS

Easily adjustable for sitting or standing, high speed or trolling.

30°

0°

### 25-30 HP TILLER KIT

### 40-130 HP TILLER KIT

1. Its exclusive lateral adjustment allows the handle to be moved 20° port or starboard for virtually any trolling application.
2. Forward-mounted, easy-to-reach shift lever.
3. Touch Troll. Easy-to-reach, adjustable idle speed switch.
4. Extended twist grip throttle with trim button on the end.
5. Additional rubber grips for improved ergonomics and control.
6. Simple, sure push-button starting.
7. Three horizontal positions, easily adjustable to give you the most comfortable angle and keep you toward the center of the seat.
8. Added security of a built-in key switch.
9. Quick, convenient push-button starting.
10. Thumb control trim and tilt right where your thumb naturally rests.
11. Easy horizontal and vertical adjustments for ultimate control and comfort.

# EVINRUDE OIL & ENGINE CARE

## GIVE YOUR ENGINE THE CARE IT DESERVES.

There is an Evinrude oil to match every engine and every sort of use. Products like our Evinrude XD100™ premium synthetic formula motor oil are designed to ensure ultimate performance and longevity.



Air, water and extreme temperatures, along with daily wear and tear, can take their toll on any outboard. Genuine Evinrude fuel conditioners, engine tuner, carbon guard, gear-case lubricants and anti-corrosion treatments will help keep your engine running strong for life.

XD-100	3.785 l
XD-100	946 ml
XD-50	3.785 l
XD-50	946 ml
XD-30	3.785 l
XD-30	946 ml



Some parts and accessories depicted may not be available (or homologated) in your country. Please contact your Evinrude dealer for more information.

# Evinrude Icon Total Control at your Fingertips.

## EVINRUDE ICON IS AN ELECTRONIC SHIFT AND CONTROL SYSTEM THAT PUTS TOTAL BOAT CONTROL AT YOUR FINGERTIPS.

**NEW STYLING** of the top-mount binnacle, with excellent ergonomics, is designed to reduce fatigue and provide smooth, predictable control.

**RELIABILITY** is built in with redundant networks and redundant sensors.

**MULTIPLE ENGINE SUPPORT** Evinrude E-TEC G2 is engineered to fit up to 4 engines.

**MULTIPLE HELM STATIONS** Single station and second station rigging for flying bridge applications.

The result is legendary ICON ergonomics with all new designs and advanced engineering for a new generation of Evinrude E-TEC G2 outboards.



SINGLE ENGINE TOP MOUNT BINNACLE CONTROL



SINGLE ENGINE CONCEALED SIDE MOUNT CONTROL

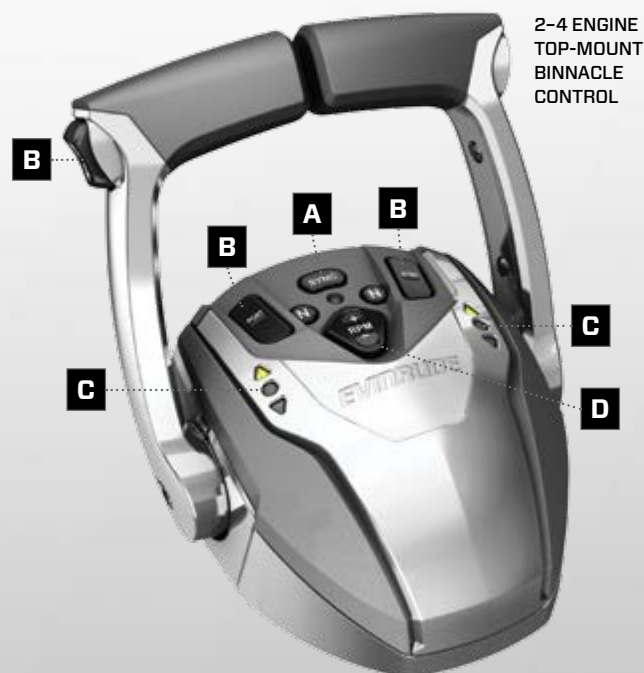

2-4 ENGINE TOP-MOUNT BINNACLE CONTROL

- A. **POWERSYNC** Synchronize multiple engine RPMs and control multiple engines by combining shift and throttle functions with the push of a button. Boat operators can now operate multi-engine boats by using a single control lever.
- B. **ENGINE TRIM** A single master engine trim switch is installed on the shift lever to control all engines. Conveniently located individual trim switches for easy operation and fine-tuning adjustments.
- C. **F-N-R INDICATORS** Forward-Neutral-Reverse (F-N-R) indicators easily identify gear position for added safety and usability. Extended twist grip throttle with trim button on the end.
- D. **RPM TUNE** This Evinrude exclusive is a virtual rpm cruise control ranging from idle to wide-open throttle. Press the "RPM" button on the control to fine-tune the engine rpm slightly higher or lower; this makes it easy to find the exact trolling speed or optimize fuel economy at cruise. Engine rpm is increased or decreased in 1% increments.

## ICON COLOR SCREENS AND TOUCH SCREENS

Specifically designed for the new Evinrude E-TEC G2 outboard, three choices of color screens—ICON TOUCH 7.0 CTS, ICON TOUCH 4.3 CTS, and ICON 3.5C—arrange and present engine and boat systems information in predefined, intuitive and uncluttered designs. All are standard programmed for dedicated presentation of Engine, Fuel/fluids, Vessel, Trip Log, and Eco View (fuel management) information.

Major functions and support include: easy access to information via color screen, or in multiple ways with the color touch screen; mode control for adjustments to power steering, trim assist and for concealed side mount, switching between hand and foot throttle operation; engine oil and accessory oil tank levels; multi-language—English, French, Italian, German, Spanish; and Notification of faults and recovery actions.

Choose the ICON COLOR SCREEN or ICON COLOR TOUCH SCREEN that best matches your boat's set-up and your personal preference for accessing information essential to an optimized boating experience.



ICON TOUCH 7.0 CTS COLOR TOUCH SCREEN



ICON TOUCH 4.3 CTS COLOR TOUCH SCREEN



ICON 3.5C COLOR SCREEN

## I-COMMAND DIGITAL

Complete, accurate information on water pressure, fuel, battery, engine hours and engine trim. Plus, you can change the format at the touch of a button—digital or analog with single, dual or quad viewing.

### INTUITIVE INFORMATION

Evinrude I-Command Digital gauges let you find the information you need when you need it. Engine and vessel information can be customized for clear accurate display. If you want digital displays—you can see it. If you want the tradition of an analog needle—you can see it. Change is good.

### FUEL MANAGEMENT FUNCTIONALITY

Fuel management has always been desired by weekend boaters as well as the most seasoned skippers. I-Command Digital gauges display fuel burned from the moment it is consumed. You can see instant MPG and remaining fuel so you know exactly how far your Evinrude E-TEC can take you. Smart, Simple, Accurate.



## ICON PRO SERIES

Increased functionality in an LCD window. Specialized functions include GPS speed, fuel management, Fuel economy, trip logs and many more.

**ICON PRO** Offers digital performance wrapped in an analog look with increased functionality in an LCD window.

**SPECIALIZED FUNCTIONS** Including GPS speed, fuel management, fuel economy, trip logs and many more.

**IT'S PLUG AND PLAY** Connects directly into the existing Evinrude NMEA 2000 network.

**VERSATILE** Works on Evinrude E-TEC 40 hp through 300 hp.

**ALL INCLUSIVE** Supports up to 5 engines and up to 4 fuel tanks.

**INTERNATIONAL** Supports multi-language.

**VISIBLE** Features anti-fog lens.

**SECURITY** Includes engine fault display.



## EVINRUDE I-DOCK

Whether you own a power catamaran, a high-performance cruiser or have an offshore center console, the i-Dock takes the stress out of docking and launching a dual-engine boat.



## FOOT THROTTLES

Experience a new level of control. Evinrude E-TEC G2 supports an accessory foot throttle—available in two variations to match most footwell designs—for easy toggling between hand and foot control using the ICON color displays. An automotive-like experience and improved 'two-handed' steering control are top among the many benefits.

# EVINRUDE PROPELLERS

## THE SAME PROPELLER DOES NOT SUIT ALL BOATS.

Choosing the right propeller is key to getting the best performance from your engine. The right propeller will get you where you want to go with optimal speed, power and efficiency. The wrong propeller will increase fuel consumption, inhibit top-end speed and can even damage your engine.

BRP offers propellers designed and developed to fit the precise specifications and performance demands of every Evinrude outboard engine.

Power-matched propellers highlight an array of genuine Evinrude parts and accessories designed to ensure maximum performance on the water.

**USE GENUINE EVINRUDE PARTS AND MAXIMIZE YOUR TIME ON THE WATER.<sup>1</sup>**



### VARIABLE VENT PORTING

Evinrude builds the new RX4 and Raker H.O. propellers with Variable Vent Ports, allowing you to custom tune acceleration power. By adjusting the opening of the vent ports, you can change the amount of bite the propeller has on acceleration.



### HIGH PERFORMANCE WITH FEW BOUNDARIES

Evinrudes' TBX hub system lets you bring high performance to any outboard engine. All of our high performing V6 stainless steel propellers are easily fitted to virtually every competitive brand of V6 outboard engine. The same is true for all Aluminum propellers for V4 and V6 engines.



**NEW**

RX4®

**NEW**

RAKER™ H.O.



ROGUE™



VIPER™ TBX™



REBEL™ TBX



HYDRUS™



CYCLONE™ TBX



SSP



ALUMINIUM

**PROPELLER SELECTION<sup>1</sup>**

Which propeller is right for your set-up?

	RX4®	RAKER™ H.O.	ROGUE™	VIPER™ TBX™	REBEL™ TBX	HYDRUS™	CYCLONE™ TBX	SSP	ALUMINIUM
PERFORMANCE	◆	◆	◆		◆				
UTILITY				◆	◆	◆		◆	◆
FISHING	◆		◆	◆	◆			◆	◆
RUNABOUT	◆		◆	◆	◆		◆	◆	◆
OFFSHORE	◆				◆		◆		
CRUISER	◆			◆	◆		◆		

1. BRP has a wide range of propellers available depending on your set-up. Consult your Evinrude dealer for the corresponding part numbers. Some models depicted may not be available in your country.

# Evinrude Engine Specifications



# Evinrude E-TEC G2



HIGH OUTPUT (H.O.)



V6

Horsepower	250 H.O.   225 H.O.   200 H.O.	300   250   225
Engine Type	V6 74° E-TEC D.I.	V6 74° E-TEC D.I.
Bore x Stroke mm (in.)	98 x 76 (3.854 x 3.000)	98 x 76 (3.854 x 3.000)
Displacement cc L (cu. in.)	3441 3.4 L (210)	3441 3.4 L (210)
Gear Ratio (shaft length) <sup>1</sup>	1.85:1	1.85:1
Full Throttle RPM Range	5400-6000 RPM	5400-6000 RPM
Weight in kg (lb.) <sup>2</sup>	244 (537)	253 (558)
Starting <sup>1</sup>	Electric	Electric
Fuel Induction	E-TEC Direct Injection with stratified low RPM combustion mode	E-TEC Direct Injection with stratified low RPM combustion mode
Alternator Output	133 Amps Total   50 net Dedicated   14 Amps @ Idle	133 Amps Total   50 net Dedicated   14 Amps @ Idle
Steering	Remote	Remote
Trim Method	Trim & Tilt	Trim & Tilt
Trim Range	-6 to 15	-6 to 15
Tilt Range	81 deg.	81 deg.
Shaft Length mm (in.)	508 (20)   635 (25)	508 (20)   635 (25)   762 (30)
Lubrication	Multipoint Targeted Oiling	Multipoint Targeted Oiling
Oil Tank Capacity L (US gal.)	Onboard 7.6 L (2) – Optional 37.9, 11.4, 6.8 L (10, 3, 1.8)	Onboard 7.6 L (2) – Optional 37.9, 11.4, 6.8 L (10, 3, 1.8)
Recommended Oil	Evinrude   Johnson XD-100 Oil	Evinrude   Johnson XD-100 Oil
Recommended Fuel	87 Octane	87 Octane
Mounting Centers cm (in.)	Minimum 66 (26)**	Minimum 66 (26)**
Steering Angle	32 deg. from center, both directions	32 deg. from center, both directions
Integrated Features L (US gal.)	Hydraulic Steering, Dynamic Power Steering*, On-Engine 7.6 L (2) Oil Tank, Dual Axis rigging, I-trim	Hydraulic Steering, Dynamic Power Steering*, On-Engine 7.6 L (2) Oil Tank, Dual Axis rigging, I-trim
Limited warranty <sup>3</sup>	5-Year Extended Limited Warranty <sup>3</sup>	5-Year Extended Limited Warranty <sup>3</sup>
Emissions Compliance	EPA 2013/CARB 3 STAR/EU 2006/EU 2016	EPA 2013/CARB 3 STAR/EU 2006/EU 2016

<sup>3</sup> On equipped models.  
<sup>\*\*</sup> Multi-rigged boats only.



### HIGH OUTPUT (H.O.)

### V6

### V4

	150 H.O.	115 H.O.	90 H.O.	200, 175, 150	130, 115
Horsepower	150 H.O.	115 H.O.	90 H.O.	200, 175, 150	130, 115
Engine Type	V6 60° E-TEC D.I.	V4 60° E-TEC D.I.	V6 60° E-TEC D.I.	V6 60° E-TEC D.I.	V4 60° E-TEC D.I.
Bore X Stroke mm (in.)	91 x 66 (3.601 x 2.598)	91 x 66 (3.601 x 2.598)	91 x 66 (3.601 x 2.598)	91 x 66 (3.601 x 2.598)	91 x 66 (3.601 x 2.598)
Displacement cc L (cu. in.)	2589 2.6 L (158.2)	1726 1.7 L (105.4)	1726 1.7 L (105.4)	2589 2.6 L (158.2)	1726 1.7 L (105.4)
Gear Ratio (shaft length) <sup>1</sup>	1.86:1	2.00:1 (508 mm / 20 in.) 2.25:1 (635 mm / 25 in.)	2.00:1 (508 mm / 20 in.) 2.25:1 (635 mm / 25 in.)	1.86:1 (508 mm / 20 in.) 1.85:1 (635 mm / 25 in.)	2.00:1 2.25:1
Full Throttle RPM Range	4850-5850 RPM	5500-6000 RPM	5500-6000 RPM	4850-5850 RPM	5500-6000 RPM
Weight in kg (lb.)	190 (418)	177 (390)(508 mm / 20 in.) 184 (405)(635 mm / 25 in.)	177 (390)(508 mm / 20 in.) 184 (405)(635 mm / 25 in.)	190 (418)	177 (390)
Starting <sup>1</sup>	Electric	Electric	Electric	Electric	Electric
Controls	Mechanical / ICON EST Digital (Acc'y)	Mechanical	Mechanical	Mech. / ICON EST Digital (Acc'y) Mech. or ICON EST Digital (150 / 200)	Mechanical
Fuel Induction	E-TEC Direct Injection with stratified low RPM combustion mode	E-TEC Direct Injection with stratified low RPM combustion mode	E-TEC Direct Injection with stratified low RPM combustion mode	E-TEC Direct Injection with stratified low RPM combustion mode	E-TEC Direct Injection with stratified low RPM combustion mode
Alternator Output <sup>3</sup>	133 Amps Total / 50 Net Dedicated <sup>4</sup>	133 Amps Total / 50 Net Dedicated <sup>4</sup>	133 Amps Total / 50 Net Dedicated <sup>4</sup>	133 Amps Total / 50 Net Dedicated <sup>4</sup>	133 Amps Total / 50 Net Dedicated <sup>4</sup>
Steering <sup>1</sup>	Remote	Remote	Remote (Tiller Accessory)	Remote	Remote (Tiller Accessory)
Trim Method <sup>1</sup>	FasTrak Power Trim and Tilt	FasTrak Power Trim and Tilt (508 mm / 20 in.), Trac-1 Power Trim and Tilt (635 mm / 25 in.)	FasTrak Power Trim and Tilt (635 mm / 25 in.), Trac-1 Power Trim and Tilt (508 mm / 20 in.)	FasTrak Power Trim and Tilt	FasTrak Power Trim and Tilt
Shaft Length mm (in.) Color (hp) <sup>1</sup>	508 (20) White   Graphite 635 (25) Graphite	508 (20) White   Graphite 635 (25) White   Graphite	508 (20) White   Graphite 635 (25) White   Graphite	508 (20) White   Graphite 635 (25) White   Graphite	508 (20) White   Graphite 635 (25) White
Limited warranty <sup>8</sup>	5-Year Extended Limited Warranty <sup>8</sup>	5-Year Extended Limited Warranty <sup>8</sup>	5-Year Extended Limited Warranty <sup>8</sup>	5-Year Extended Limited Warranty <sup>8</sup>	5-Year Extended Limited Warranty <sup>8</sup>
Emissions Compliance	EPA 2013/CARB 3 STAR/EU 2006	EU 2006	EPA 2013/CARB 3 STAR/EU 2006	EPA 2013/CARB 3 STAR/ EU 2006 (150/175) EPA 2013/CARB 2 STAR/ EU 2006 (200)	EPA 2013/CARB 3 STAR/EU 2006 (115) EU 2006 (130)

1 May vary based on engine model number.

2 Weight refers to the actual weight (including all fluids) for the lightest model/version of each horsepower listed in that grouping.

3 Rope-start-only models require optional charging accessory kit.

4 Variable Voltage Computer Controlled 133 A. Current A calculated at 13.5 V. Net dedicated battery charging power output is 50 A.

5 Variable Voltage Computer Controlled 81 A. Current A calculated at 13.5 V. Net dedicated battery charging power output is 25 A.

6 56 A. Current A calculated at 13.5 V. Net dedicated battery charging power output is 15 A.

7 Electric also has rope capabilities.

8 BRP 5 Year (Standard 3 + 2) Extended Limited Warranty Programme. For full details and conditions see page 41.

**Note:**  
Counter Rotation Gearcase with Power Trim & Tilt available on 300-, 250-, 225-, 200-, 175-, 150-, 130- and 115-hp engines (excludes High Output models).



### INLINE 3-CYL.

### INLINE 2-CYL.

### PORTABLE

90, 75	60, 50, 40	30, 25	15, 9.8, 6, 4, 3.5
Inline 3-cyl. E-TEC D.I.	Inline 2-cyl. E-TEC D.I.	Inline 2-cyl. E-TEC D.I.	2-cylinder, 1-cylinder
91 x 66 (3.601 x 2.588)	91 x 66 (3.601 x 2.588)	76 x 64 (2.992 x 2.5)	2.4 x 2.36 (61 x 60) 2.17 x 1.7 (55 x 44) 2.32 x 1.77 (59 x 45) 2.17 x 1.42 (55 x 36)
1295 1.3 L (79.1) Inline 3	863 1.0 L (52.7) Inline 2	577 1.0 L (35.2) Inline 2	21.41 (351), 12.8 (209) 7.5 (123), 5.2 (85.5)
2.00:1(508 mm / 20 in.) 2.25:1(635 mm / 25 in.)	2.67:1	2.15:1	2.15:1 2.08:1
4500-5500 RPM	5500-6000 RPM	5500-6100 RPM	4500-6000 RPM
145 (320)	109 (240) (50, 40) 113 (250) (60)	66 (146)	52 (114.4), 37 (81.5), 25 (55), 26 (57), 18.4 (41)
Electric	Electric or Rope (40 only)	Electric or Rope <sup>7</sup>	Electric or Manual
Mechanical	Mechanical	Mechanical	Remote Control or Tiller Handle
E-TEC Direct Injection with stratified low RPM combustion mode	E-TEC Direct Injection with stratified low RPM combustion mode	E-TEC Direct Injection with stratified low RPM combustion mode	Carbureted
81 Amps Total / 25 Net Dedicated <sup>5</sup>	81 Amps Total / 25 Net Dedicated <sup>5</sup>	56 Amps Total / 15 Amps Net Dedicated <sup>6</sup>	Only on Electric models: 12V, 60 W, 5 A 12V, 80 W, 5 A 12V, 145 W, 12 A
Remote (Tiller Accessory)	Remote or Tiller (Tiller Accessory)	Remote or Tiller	Tiller or Remote
FasTrak Power Trim and Tilt	Power Trim and Tilt or Manual Tilt (40 only)	Power Trim and Tilt or Manual Tilt	Manual or Power Tilt
508 (20) White   Graphite 635 (25) White   Graphite (90 only)	508 (20) White   Graphite	381 (15) White   Graphite 508 (20) White   Graphite	381 (15) Blue 508 (20) Blue 635 (25) Blue
5-Year Extended Limited Warranty <sup>8</sup>	5-Year Extended Limited Warranty <sup>8</sup>	5-Year Extended Limited Warranty <sup>8</sup>	3-Year Warranty
EPA 2013/CARB 3 STAR/EU 2006	EPA 2013/CARB 3 STAR/EU 2006	EPA 2013/CARB 3 STAR/EU 2006	EPA 2013/CARB 3 STAR/EU 2006 (15)



**(8) Warranty: BRP 5 YEAR (STANDARD 3 + 2) EXTENDED LIMITED WARRANTY PROGRAMME:** (offered only through BRP European Distribution SA and its authorised BRP dealers for Evinrude® outboard engines that are sold to residents of the European Union for recreational use only). This Extended Limited Warranty Programme adds 24 months of BRP Limited Warranty coverage beyond the standard 36 month BRP Warranty (limited to 750 Hrs and 1000 Hrs on G2 Models whichever occurs first) applicable to Evinrude outboard engines provided these Special Conditions are met: **Qualification:** A qualifying Evinrude outboard engine must be purchased by an EU resident and warranty registered to that resident FOR RECREATIONAL USE ONLY by an authorized BRP dealer or BRP OEM business partner on or after September 27, 2010. Qualifying Evinrude outboard engines include all new and unused Evinrude engines of model year 2010 and higher. Accessories, gauges and rigging components and related parts are not included in this Extended Limited Warranty Program. Demo units that were registered by an authorized BRP dealer upon invoicing by BRP will be eligible for this program provided all other conditions apply. **Inspection/Service/Maintenance:** The BRP specified pre-delivery inspection process for the Evinrude outboard engine MUST BE completed and documented (see your BRP Service booklet – Service Records section) by your authorized BRP dealer. The service intervals and maintenance recommendations for the outboard engine MUST BE adhered to including the specific maintenance recommendations in the applicable BRP Operator's Guide. This includes all recommended inspections and maintenance performed by an authorized BRP dealer during and following the initial 36 month BRP Limited Warranty period. Use in salt water and heavy use may require specific maintenance and more frequent inspection as outlined in the applicable BRP Operator's Guide. All services (including winterization and pre-season inspection) must be recorded in your Evinrude Service booklet by your authorised BRP dealer. BRP reserves the right to request maintenance records to ensure qualification for this program. ONLY BRP Evinrude certified parts, oils and lubes must be used for service and repairs of the Evinrude outboard engine during the entire eligible period for this program to apply. BRP certified parts may include BRP new or remanufactured parts and components. BRP reserves the right to repair or replace any warranted unit in its sole discretion. The standard BRP Limited Warranty for service parts and accessories applies and is not extended through this program. Improper maintenance and/or use of parts and accessories not manufactured or approved by BRP will cancel this Extended Limited Warranty program. This may also affect your rights under the standard BRP Limited Warranty. **Modification/Alteration:** Evinrude parts and outboard engines that have been modified or altered from their original production configuration are NOT ELIGIBLE for this BRP Extended Limited Warranty Program and shall disqualify an Evinrude outboard engine from continuation in this program.

Fuel economy: Fuel economy claims are based on laboratory tests utilizing ISO 8178-4 and boat tests performed at BRP facilities. Actual fuel usage will vary depending on the boat, payload, operating conditions, propeller and driving habits. Power Ratings Evinrude outboards are power rated in accordance with National Marine Manufacturer's Association (NMMA) procedure using International Council Marine Industry Associates (ICOMIA) standard 28/83. Specifications: In furtherance of our policy of continual product improvement, we reserve the right to discontinue, substitute, change or improve the design of any outboard motor at any time, without assuming obligation to modify motors previously manufactured. We reserve the right, at any time, to discontinue or change specifications, price, designs, features, models or equipment without incurring obligation. The information in this brochure is based on the latest specifications available at the time of printing. See your Evinrude dealer for the latest product information. Some models depicted herein may contain accessories or be shown with options which are available at an extra cost from your Evinrude dealer. Engine performance may vary depending on, among other things, general conditions, ambient temperature, ability, options, modifications and driver and passenger payload weight, engine type, and optional equipment. Product availability and warranty may vary depending on the region. For advertising purposes, some pictures in this brochure include professional drivers executing manoeuvres under ideal and/or controlled conditions. Do not attempt any of these, or any other risky manoeuvres, if they're beyond your level of driving ability. Always consult your local dealer when selecting an outboard for your particular needs and carefully heed and pay special attention to your Operator's Guide and the on-product labelling. Always drive responsibly and safely. Severe injury can result from ignoring warnings, not following the instructions, or improper use of boats and engines. Use common sense and courtesy. Always observe applicable local laws and regulations. Respect the right of, and keep a safe distance from other recreationists, bystanders and the shoreline.





Your boating style. Your water.  
Your all-around experience.  
There's an Evinrude outboard  
built to make it or match it  
all... perfectly.



# THE WORLD IS OUR PLAYGROUND

Nothing is more valuable than your playtime. That is why BRP is dedicated to continually finding new and better ways to help you enjoy your favourite power sports. From snow to water to both on- and off-road fun, our passion for adventure fuels the innovations that result in the ultimate power sports experience for our customers. We value



the land and water we play on and are committed to protecting it. Our desire to thrill is paired with an emphasis on rider responsibility, placing personal safety above all else. So that each outing can be the most enjoyable, memorable and thrilling experience possible. Because your free time should always be your best time.

[www.brp.com](http://www.brp.com)



SKI-DOO® LYNX® SEA-DOO® EVINRUDE® JOHNSON® ROTAX® CAN-AM®